

Best practice guidance

Drylining to facilitate building movement

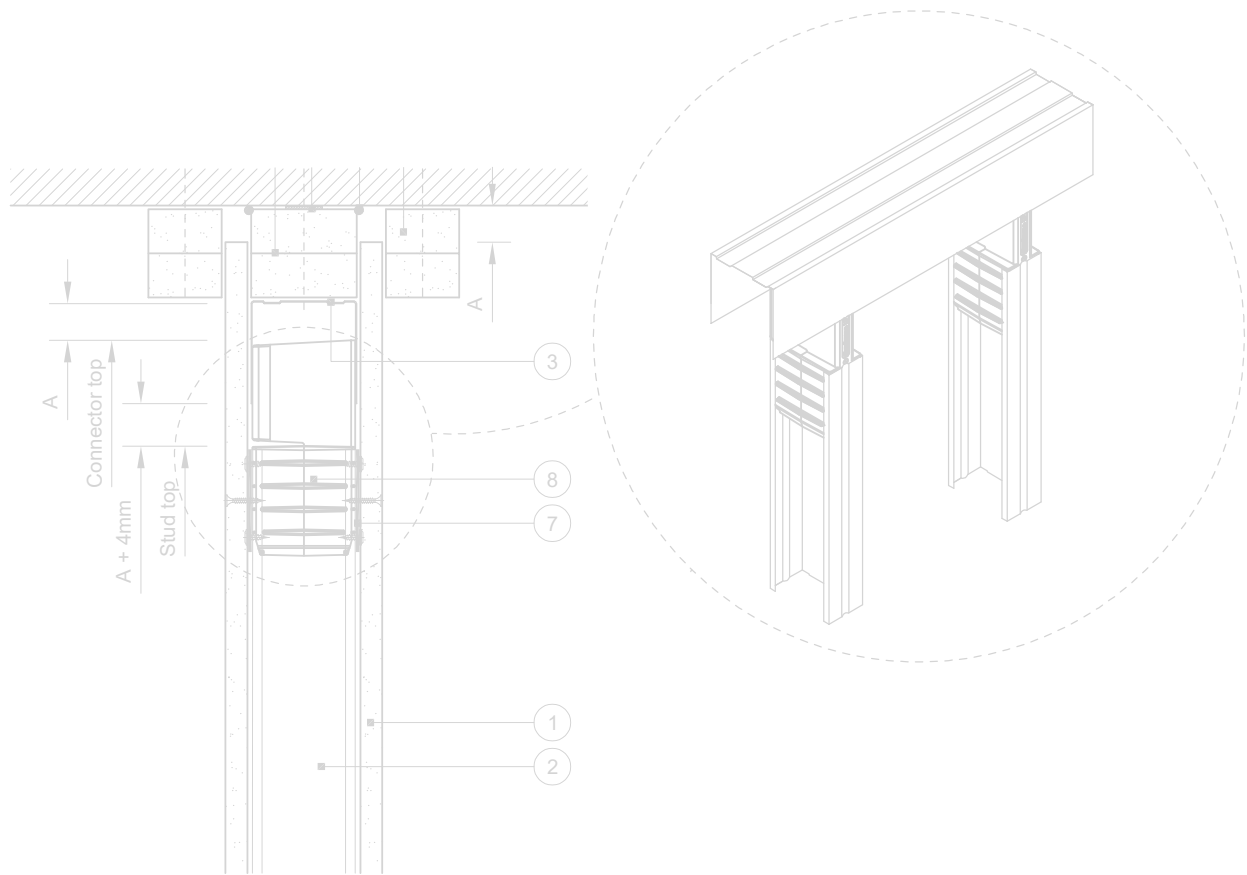

12 January 2026

BPG003

Technical Support Team

East Leake Loughborough Leicestershire LE12 6HX

Tel: 0115 945 6123 british-gypsum.com

Contents

3	Introduction
4	Best practice guidance
5	Good practice guidance for installation of Gypframe LF7 Connectors
8	Good practice guidance for installation of Fric-Lo® 2020 5M Instant Friction Reduction Tape
13	Examples of good and bad installation practice for Gypframe LF7 Connectors
15	Examples of good and bad installation practice for Fric-Lo®
17	Details to minimise the risk of the consequences of movement
	Section A – Walls
18	- Detail 1 – GypWall Single Frame with Gypframe LF7 Connector
19	- Detail 2 – GypWall Single with Fric-Lo® 2020 5M Instant Friction Reduction Tape
20	- Detail 3 – GypWall Twin Frame systems detail
21	- Detail 4 – GypWall Shaft
	Section B – Ceilings
22	- Detail 5 – GypCeiling MF with floating perimeter
23	- Detail 6 – GypWall Single Frame junction with GypCeiling MF
	Section C – Abutments to superstructure
24	- Detail 7 – Rip of plasterboard
25	Revisions

Over the last 30 years, improvements in design, material and construction methods have in combination with changes in the building regulations enabled the delivery of increasingly taller and more slender buildings for both commercial and residential use.

Typically, tall, modern structural designs allow for greater building movement than smaller, lower rise designs to allow buildings to be more resilient to environmental conditions.

A significant increase in demand for technology from heating and lighting control to building management systems has increased the amount of mechanical and electrical services (M&E) in buildings, resulting in the interior systems having to adapt to suit these ever-changing demands.

While the structural elements of the buildings have become lighter and more flexible, how we create internal spaces has evolved in a different way, focussing on the delivery of durability, acoustic comfort and fire compartmentation.

A consequence of these different approaches was highlighted in work completed by the Finishes & Interiors Sector (FIS) Tall Building Working Group* which concluded that

- *“External loads make the building move: non-structural elements should be installed in such a way as to allow for the movements freely.”*
- *“Any locked in movement will cause distress in the non-structural elements.”*
- *“Any frictional resistance to movements will cause noise.”*

And furthermore

“The key to reducing the phenomenon occurring in future tall towers is sharing the information contained in the structural engineer’s movement and tolerance reports early with the system owners of the drylining, and providing movement joints to allow the elements of the internal fit out to move independently.”

The purpose of this guide is to supplement “BPG002 Best Practice Guidance: Deflection Heads” where the topic of axial (vertical) deflection is covered extensively.

As shown in the FIS report, both vertical (e.g. live and dead loads) and horizontal (lateral, e.g. inter-story drift) movement can occur. This guide summarises our current best practice guidance within our systems for facilitating vertical building movement, including some specific details for reducing the risk of consequences of relative movement between building elements.

Good design and install practices are key to ensuring all of the desired specified performances are met. The details contained within this guide are about creating optimal conditions to minimise risk of consequences of movement. All other performances must be considered when designing and installing our systems; this includes, but is not limited to fire, structural (maximum height) and acoustic performances. It is the responsibility of the design and management authority relevant to the project to satisfy themselves that all necessary performance requirements have been met.

Many of the internal non-structural construction elements (for example plumbing, mechanical, electrical, heating and ventilation) could have undesirable consequences resulting from resisting building movement, including the potential to create noise. These are not within the control of the drylining designer or installer and cannot be considered in any detail for this guidance.

Where systems by others interact with our drylining systems, design consideration must be given to the interaction between building elements for all performances, including the potential to resist movement. It is the responsibility of the design and management authority relevant to the project to satisfy themselves that all necessary performance requirements have been met.

* <https://www.thefis.org/knowledge-hub/technical/tall-buildings-research/>

Best practice guidance

Installing partitions and ceilings right first time, every time, is the goal of every contractor. Errors in installation can cause delays in the build programme, loss of quality and failure to meet design performance. All of these add up to cause client dissatisfaction and increased costs.

It must be noted that the range of unintended forces being applied to a partition as a result of structural movement due to wind loading on tall buildings are complex in their nature and outside the scope of the partition system design. As such, British Gypsum is unable to offer an opinion on the long-term effect of these forces on the integrity of its systems. Damage or performance loss witnessed by the partition as a result of these forces over time will fall outside the scope of the **SpecSure**® lifetime system warranty.

This guide has been developed by working with specialist contractors and site management teams to understand the installation issues that occur most frequently on tall building sites and cause day-to-day problems on their projects.

General site guidance

We recognise the importance of always following good site practice. In this section we detail general site guidance outlining safe practice for handling and storing British Gypsum products and systems, helping you to work better and stay safe. These notes are for guidance purposes only and are not intended to be exhaustive. We advise that you read and familiarise yourself with all of the relevant information in this guide prior to commencement of work. Where other manufacturers' products or systems are being used in association with our systems, reference should always be made to the manufacturer's own installation instructions and product data.

The following documents have been used as reference in the creation of this guide and should be considered as essential supplementary reading for a complete overview on the topic.

1. BPG001 Best Practice Guidance: Openings within Fire Rated Systems
2. BPG002 Best Practice Guidance: Deflection Heads
3. BS 8000-8:2023 Workmanship on Construction Sites, Part 8: Design and Installation of Drylining Systems - Code of Practice (with attention to specific sections below)
 - 7.1.1 Selection of a drylining system
 - 7.4.6 Ability to accommodate movement
 - 7.4.6.4.1 General
 - 7.4.6.4 Lateral movement
 - 7.5 Deviations and tolerances
 - 7.9 Environmental conditions
 - 8 Installation
4. FIS Report: Designing for Tall Building Movement (A Short Guide)*

For all the following guidance details the site conditions below are applicable:

1. All substrates shall be level, regular and free of residue, debris and surface defects. All defects which may lead to the deformation of channels and studs during installation will be rectified prior to commencement.
2. All metal profiles used in the installation will be straight, true and cuts formed to avoid abrasion where movement between components may occur.

Good practice guidance for installation of Gypframe LF7 Connectors

This method is based upon use of the system within a 25mm deflection head, specified systems only.

Gypframe LF7 Connectors are designed and tested to work within British Gypsum Gypframe Studs only. Please ensure you have the correct connector size to suit your stud and channel combination.

Gypframe LF7 Connectors must not be used in external walls, as they do not satisfy the required reaction to fire performance.

- Cut studs to the correct length accounting for the deflection and the length of the connector. Connectors must only be inserted into the factory cut end of the stud.
- For Gypframe 'C' Studs, the Gypframe LF7 Connector is inserted within the flanges and web of the stud.
- For Gypframe 'I' Studs, the Gypframe LF7 Connector is inserted over the web of the stud such that the slot in the connector engages with the web, and between the flanges.
- Ensure that all the stud surfaces are clean, dry and free of any contaminants.

- Using puncture-resistant protective gloves, hand insert the Gypframe LF7 Connector into the factory cut end of the stud.
- For Gypframe 'C' Studs, the connector can only be correctly inserted one way with ridges facing away from the stud web.
- Do not use excessive force to insert the Gypframe LF7 Connector. The connector "wings" will click until the connector is fully inserted and the stop end is flush with the stud end.
- The head of the stud with connector attached must be inserted into the head channel first before the bottom is twisted into place.
- Locate the stud within the base channel and the Gypframe LF7 Connector within the Gypframe Head Channel, and twist to locate as per standard install practice.
- Care must be taken to ensure the proper deflection gap is allowed above the connector before commencing boarding.

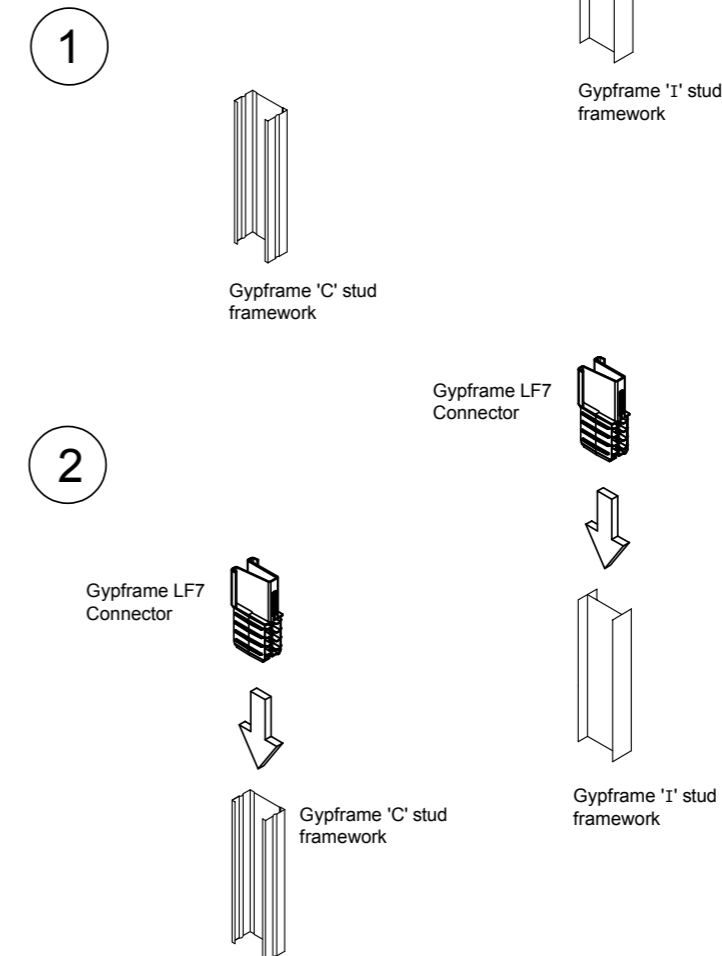

* <https://www.thefis.org/members-login/?redirect=/wp-content/uploads/2019/12/TBWG-WSP-ZZ-RP-S-0002-rev-01.pdf>

Best practice guidance

Drylining to facilitate building movement

Good practice guidance for installation of Gyframe LF7 Connectors

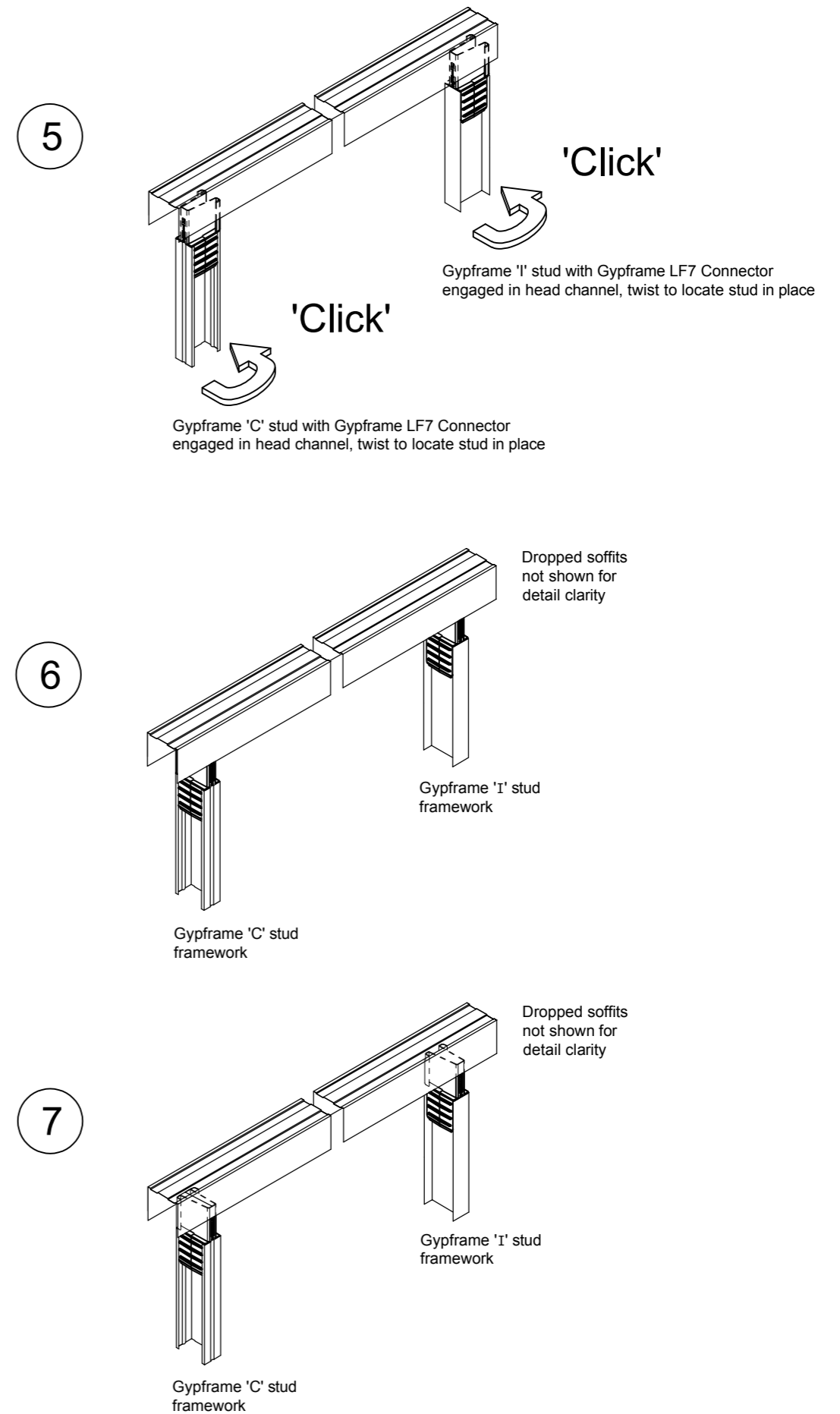
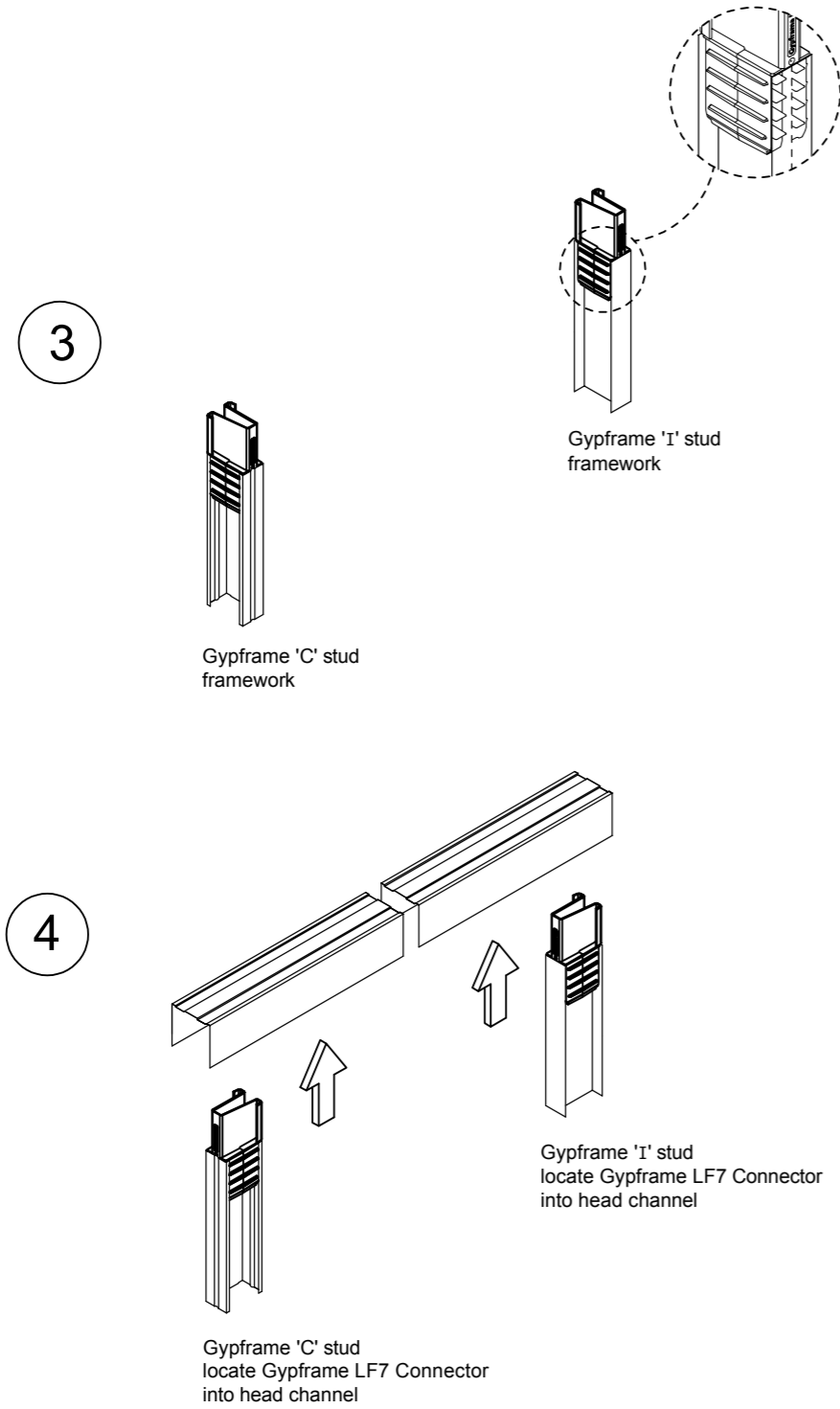

Best practice guidance

Drylining to facilitate building movement

Good practice guidance for installation of Fric-Lo® 2020 5M Instant Friction Reduction Tape

Part 1: This method is based upon sections of tape being applied to the stud only.

- Ensure that all the stud surfaces are clean, dry and free of any contaminants.
- Apply a section of the Fric-Lo® 2020 5M Instant Friction Reduction Tape to each flange of the studs at the factory cut end of the stud.
- Using puncture-resistant protective gloves, hand apply firm pressure over the whole area of tape. Any overhanging pieces of the tape should be pressed firmly around the edges of studs. Please ensure that the tape covers the whole of the flange width and extends to the top of the stud leaving no metal exposed.
- Locate the factory cut end of the stud within the head channel. If this cannot be done then ensure that all steel burrs are removed from the site cut end of the stud.
- The longer the tape is left after application the better the adhesion. For best practice, apply the sections to the factory cut ends of the studs prior to framework installation to allow for a tack time in the region of five minutes. 24 hours is a rough guide for pressure sensitive adhesives to “wet out” and achieve maximum adhesion.
- The head of the stud must be inserted into the head channel first before the bottom is twisted into place.

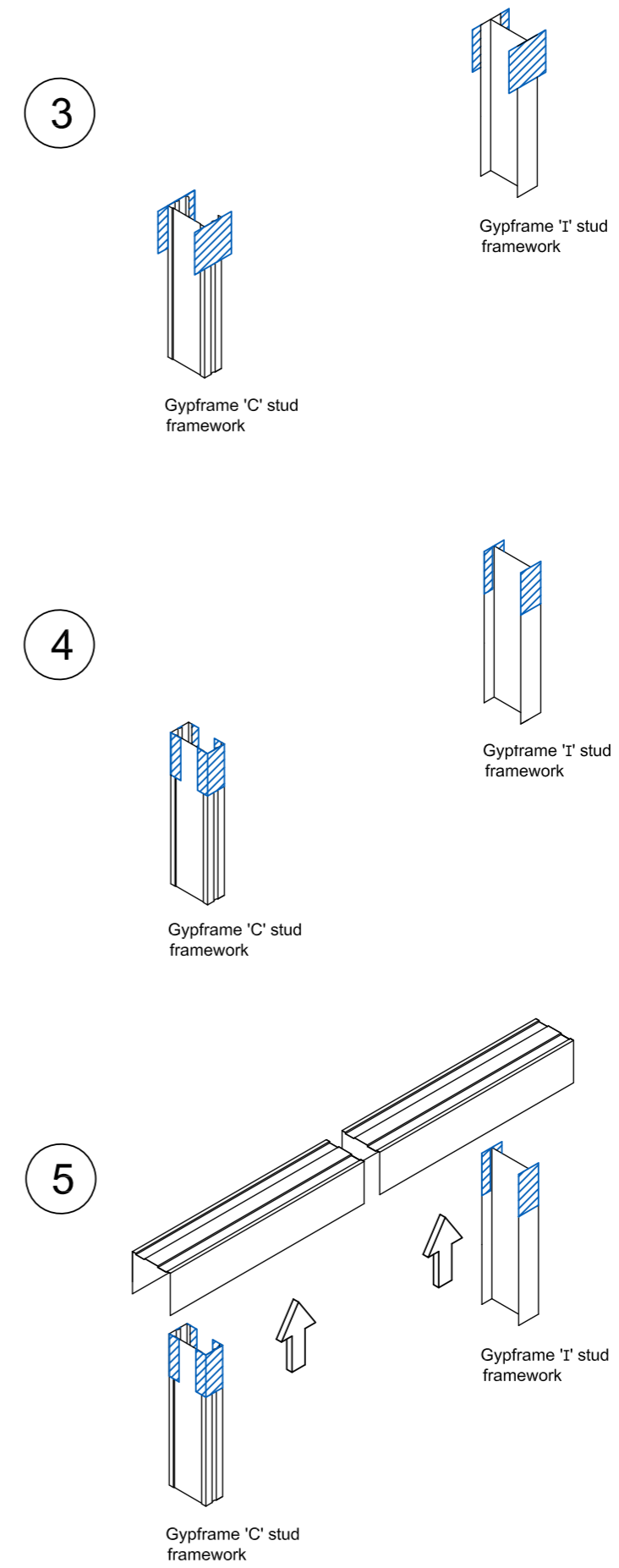
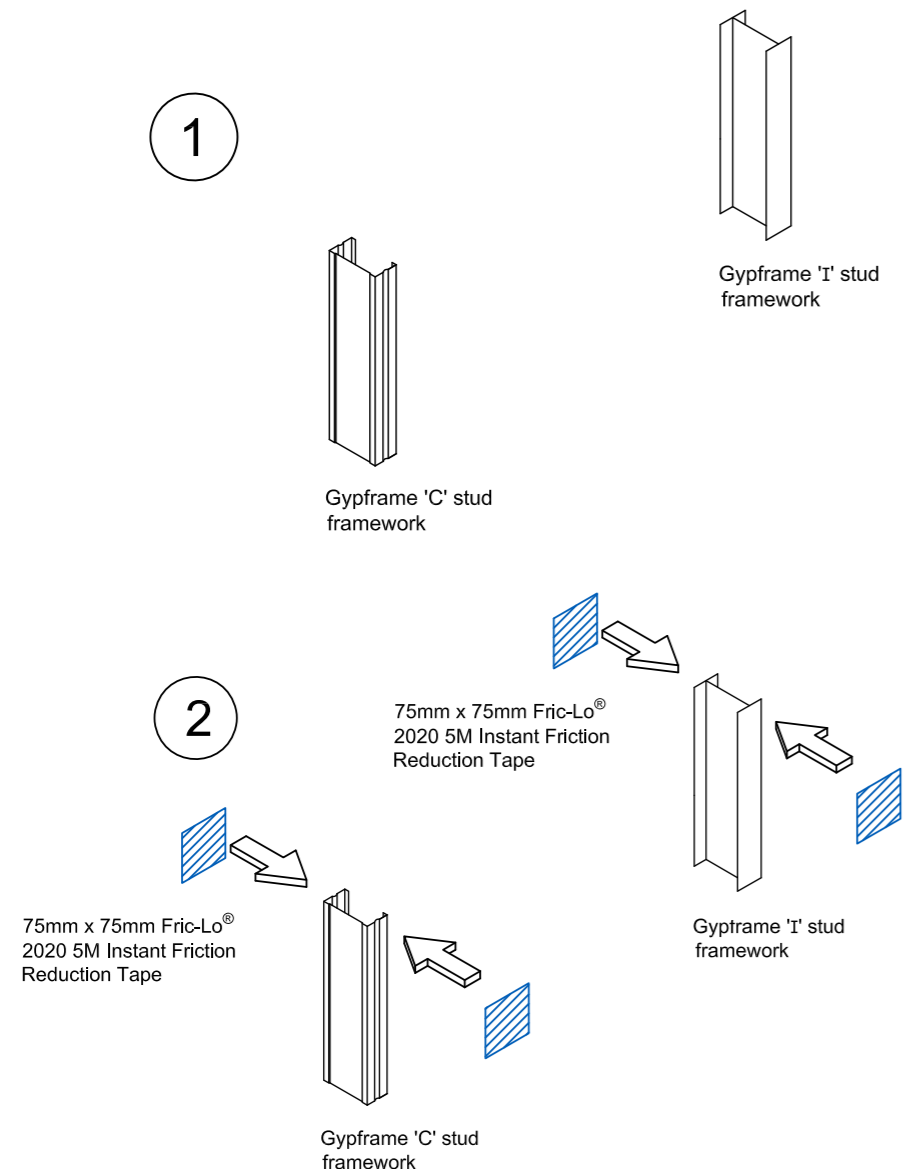

* <https://www.thefis.org/members-login/?redirect=/wp-content/uploads/2019/12/TBWG-WSP-ZZ-RP-S-0002-rev-01.pdf>

Good practice guidance for installation of Fric-Lo® 2020 5M Instant Friction Reduction Tape

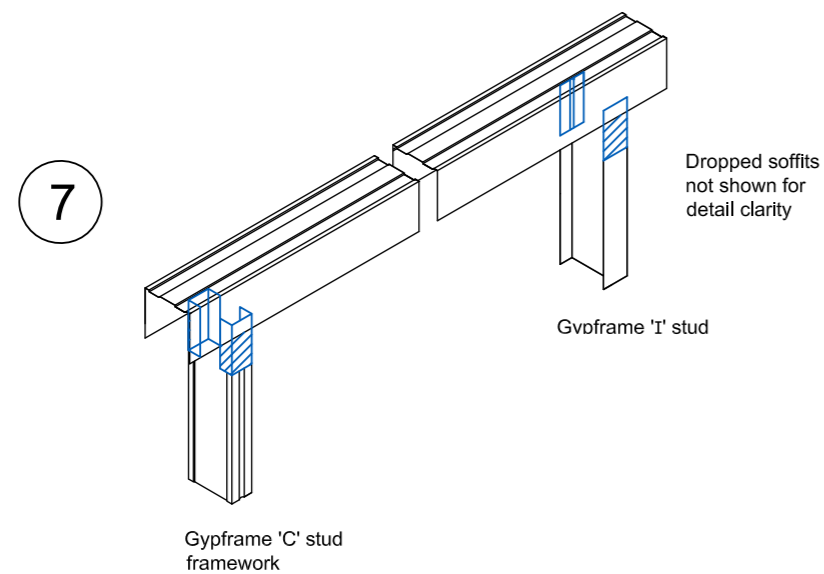
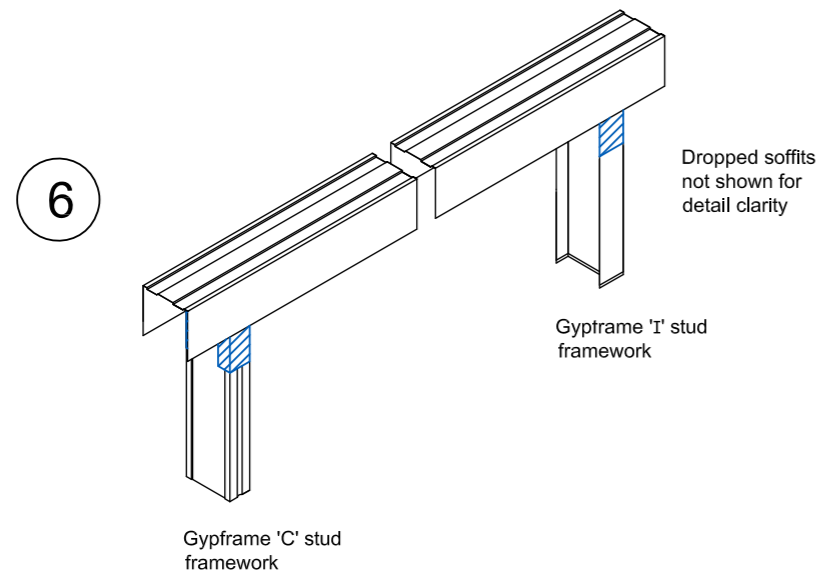

Part 2: This method is based upon applying continuous lengths of tape to the channel only.

- 1) Ensure that all the internal flange surfaces of the channel are clean, dry and free of any contaminants.
- 2) Apply a continuous length of Fric-Lo® 2020 5M Instant Friction Reduction Tape to both internal flange faces of the head channel.
- 3) Using puncture-resistant protective gloves, hand apply firm, smooth pressure over the whole area of tape.
- 4) Any overhanging pieces of the tape should be pressed firmly around the edges of the channel. Please ensure that the tape covers the whole of the internal flange faces.
- 5) The longer the tape is left after application the better the adhesion. For best practice, apply the lengths of tape to the channel prior to framework installation to allow for a tack time in the region of five minutes. 24 hours is a rough guide for pressure sensitive adhesives to “wet out” and achieve maximum adhesion.
- 6) The head of the stud must be inserted into the head channel first before the bottom is twisted into place. Locate the factory cut end of the stud within the head channel. If this cannot be done then ensure that all steel burrs are removed from the site cut end of the stud.

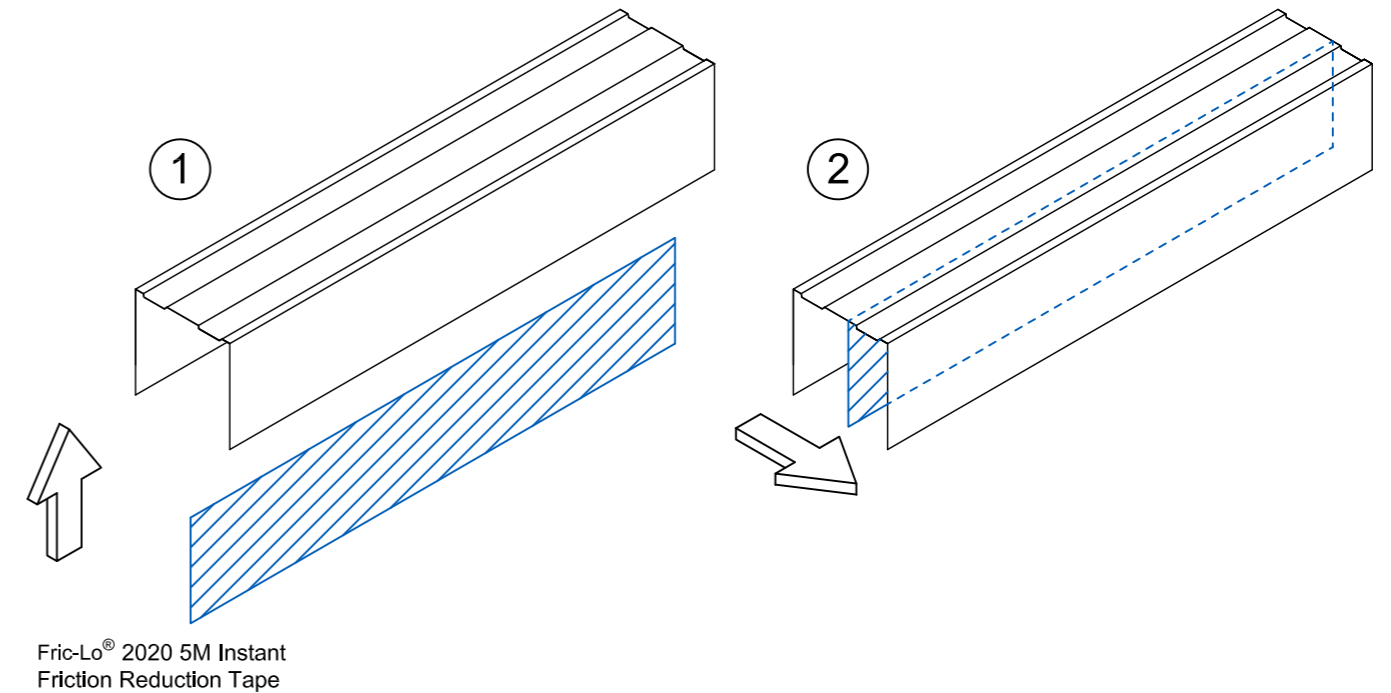

Best practice guidance

Drylining to facilitate building movement

Good practice guidance for installation of Fric-Lo® 2020 5M Instant Friction Reduction Tape

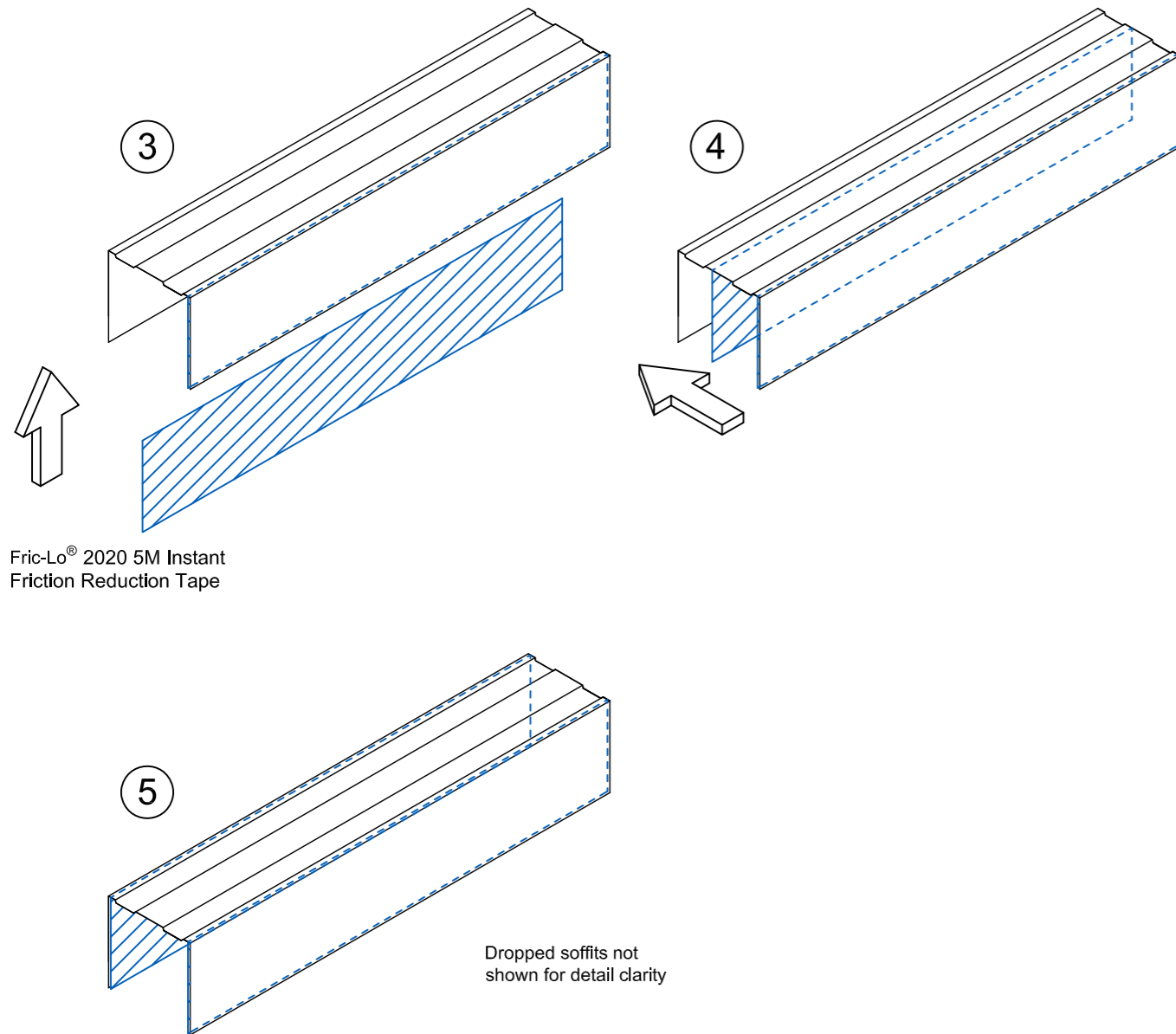

Examples of good and bad installation practice for Gyproframe LF7 Connectors



Gyproframe LF7 connectors must be inserted observing the deflection allowance at the head, and never fully inserted into the channel web.



Gyproframe LF7 Connectors are designed to only fit one way, excessive force must not be used to insert them into studs.

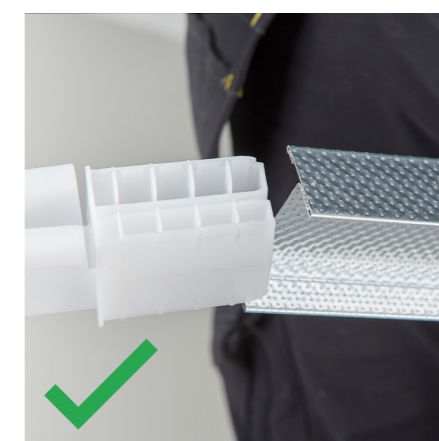

Always fully insert the connector into the stud.

Gyproframe LF7 Connectors only work with the corresponding size 'I' or 'C' profile studs from the British Gypsum range.

Best practice guidance

Drylining to facilitate building movement

Examples of good and bad installation practice for Gypframe LF7 Connectors

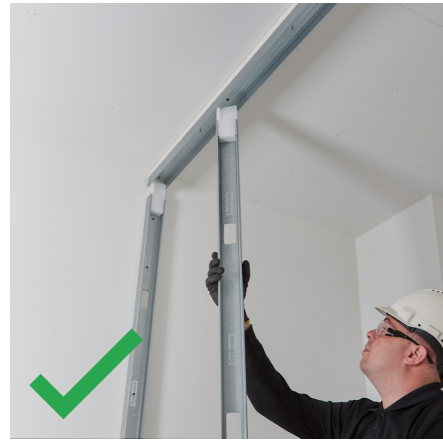

Once installed, twist the connector into the head track before twisting the stud into the base track.



Gypframe LF7 Connectors work with Gypframe GFS1 Fixing Strap.



For the best connection, ensure the stud flanges are not flared outward before inserting the connector.

Examples of good and bad installation practice for Fric-Lo®



Installing the Fric-Lo® 2020 5M Instant Friction Reduction Tape to the stud ensuring smooth application and adhesion.

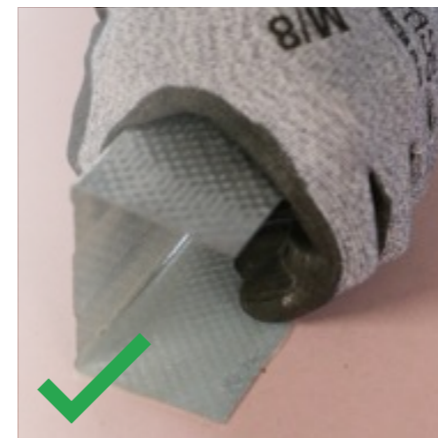

Installing the Fric-Lo® 2020 5M Instant Friction Reduction Tape to the channel ensuring smooth application and adhesion.



Locating head of stud in head channel prior to base of stud in base channel.

Best practice guidance

Drylining to facilitate building movement

Examples of good and bad installation practice for Fric-Lo®

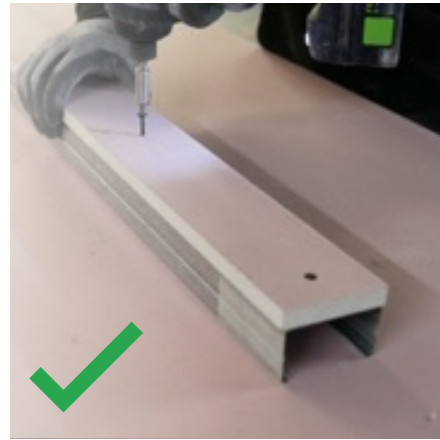

Pre-fix plasterboard rip/strip to stud web prior to fixing stud to wall.

This abutment detail limits the contact between drylining steel frame and building structural elements. A “softer” joint may help to reduce energy transferred between structural elements and the drylining.

Details to minimise the risk of the consequences of movement

Good design and install practices are key to ensuring all of the desired specified performances are met. The following details are about creating optimal conditions to minimise risk of consequences of movement. All other performances must be considered when designing and installing our systems; this includes, but is not limited to fire, structural (maximum height) and acoustic performances. It is the responsibility of the design and management authority relevant to the project to satisfy themselves that all necessary performance requirements have been met.

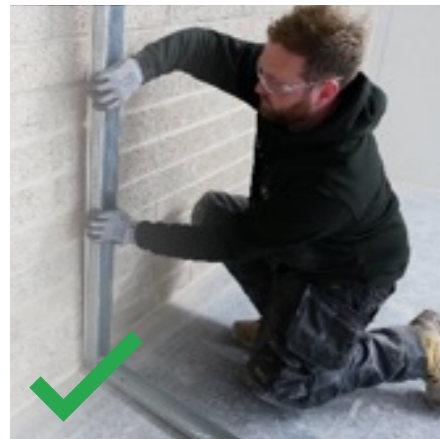

Using a factory cut end with Fric-Lo® 2020 5M Instant Friction Reduction Tape.

A factory cut end will have fewer burrs, and is more likely to be straight and true, helping to avoid abrasion between elements.

Section A – Walls

Detail 1 – GypWall Single Frame with Gypframe LF7 Connector

- 1 One layer Gyproc SoundBloc 12.5mm fixed with British Gypsum Drywall Screws 25mm at 300mm centres (200mm centres at external angles).
- 2 Gypframe 70 S 50 'C' Studs at 600mm centres.
- 3 Gypframe 72 EDC 80 Extra Deep Flange Floor & Ceiling Channel, suitably fixed through board to soffit at 600mm centres.
- 4 Gyproc Sealant for optimum sound insulation.
- 5 Gyproc FireStrip.
- 6 Two 72mm width strips of 30mm Glasroc F Firecase.
- 7 Gypframe GFS1 Fixing Strap fixed to each stud with two British Gypsum Wafer Head Drywall Screws to receive uppermost board fixings (no fixings into head channel).
- 8 Gypframe LF7 Connector.
- 9 Two 50mm width strips of Glasroc F FireCase 30mm fixed to soffit with suitable fire resistant fixings at 600mm centres.

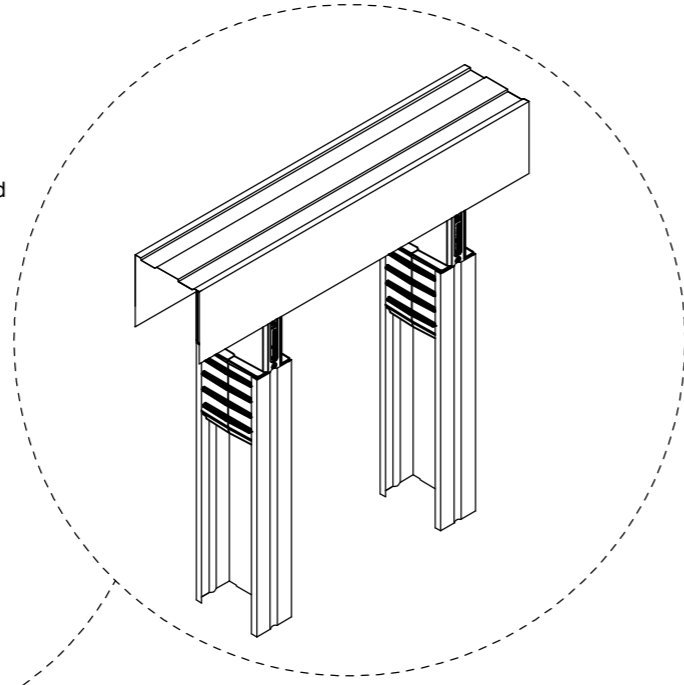
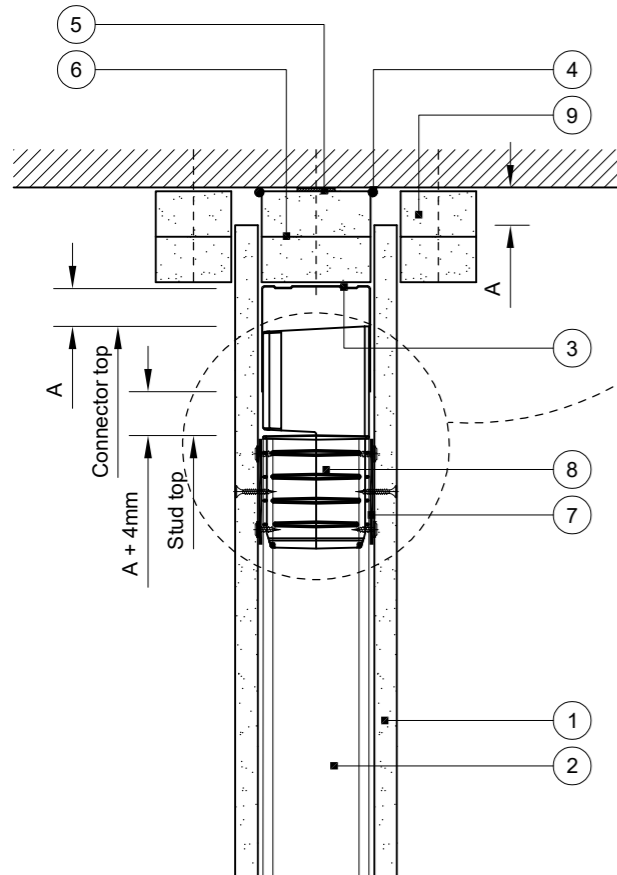

Deflection head

Downward (vertical) movement

A = Required project vertical deflection, to be determined by Structural Engineer, detail maximum 50mm downward or +/-25mm.

Section A – Walls

Detail 2 – GypWall Single Frame and GypWall Single Frame Enhanced with Fric-Lo® 2020 5M Instant Friction Reduction Tape

- 1 GypWall partition deflection head detail as per project specification and required movement as determined by Structural Engineer, please refer to British Gypsum standard details.
- 2 GypWall Partition System as per project specification and British Gypsum standard details.
- 3 75mm x 75mm Fric-Lo® 2020 5M Instant Friction Reduction Tape applied to top of each stud, on both flanges prior to location of studs within head channel.

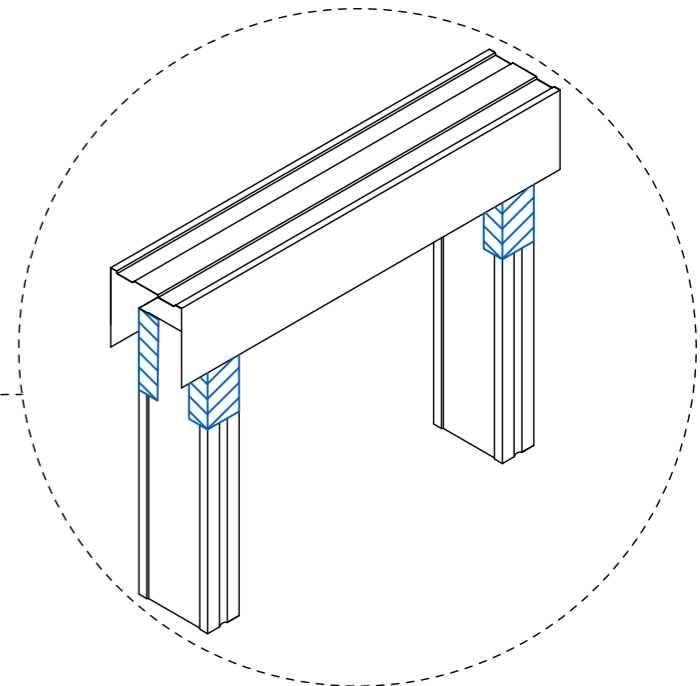
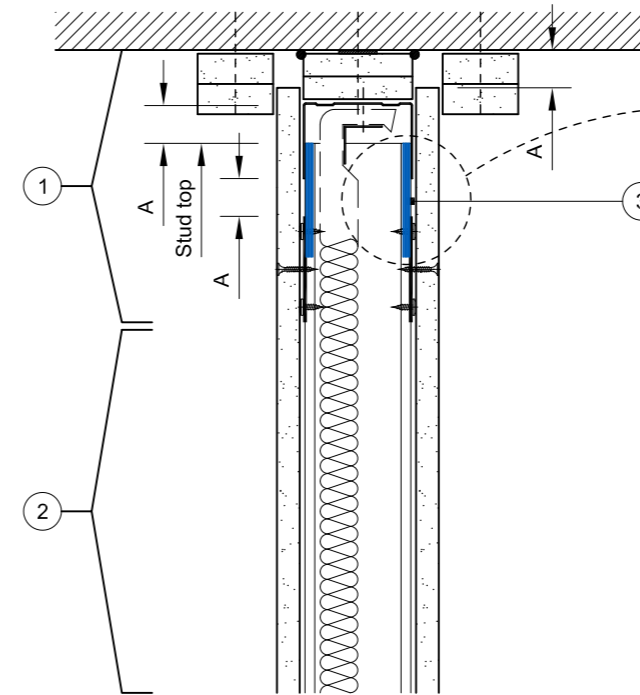

Deflection head

Downward (vertical) movement

A = Required project vertical deflection, to be determined by Structural Engineer, please refer to British Gypsum standard details for further guidance on permitted range of movement and detail configuration.

Section A - Walls

Detail 3 - GypWall Twin Frame Systems

- 1 GypWall Twin Frame partition deflection head detail as per project specification and required movement as determined by Structural Engineer, please refer to British Gypsum standard details.
- 2 GypWall Twin Frame Partition System as per project specification and British Gypsum standard details.
- 3 75mm x 75mm Fric-Lo® 2020 5M Instant Friction Reduction Tape applied to top of each stud, on both flanges prior to location of studs within head channel.

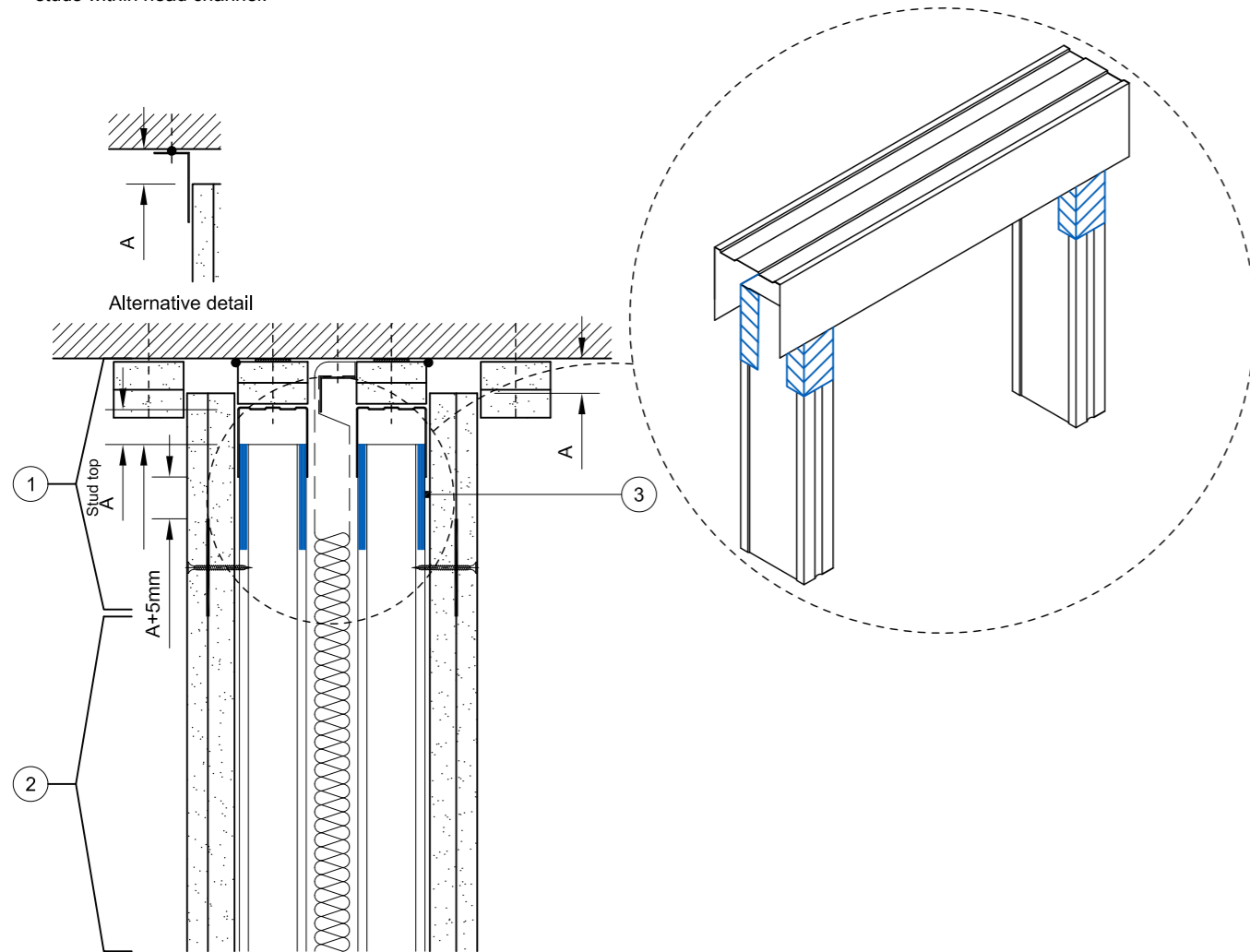

Deflection head

Downward (vertical) movement

A = Required project vertical deflection, to be determined by Structural Engineer, please refer to British Gypsum standard details for further guidance on permitted range of movement and detail configuration.

Section A - Walls

Detail 4 - GypWall Shaft

- 1 GypWall Shaft deflection head detail as per project specification and required movement as determined by Structural Engineer, please refer to British Gypsum standard details.
- 2 GypWall Shaft system as per project specification and British Gypsum standard details.
- 3 75mm x 75mm Fric-Lo® 2020 5M Instant Friction Reduction Tape applied to top of each stud, on both flanges prior to location of studs within head channel.

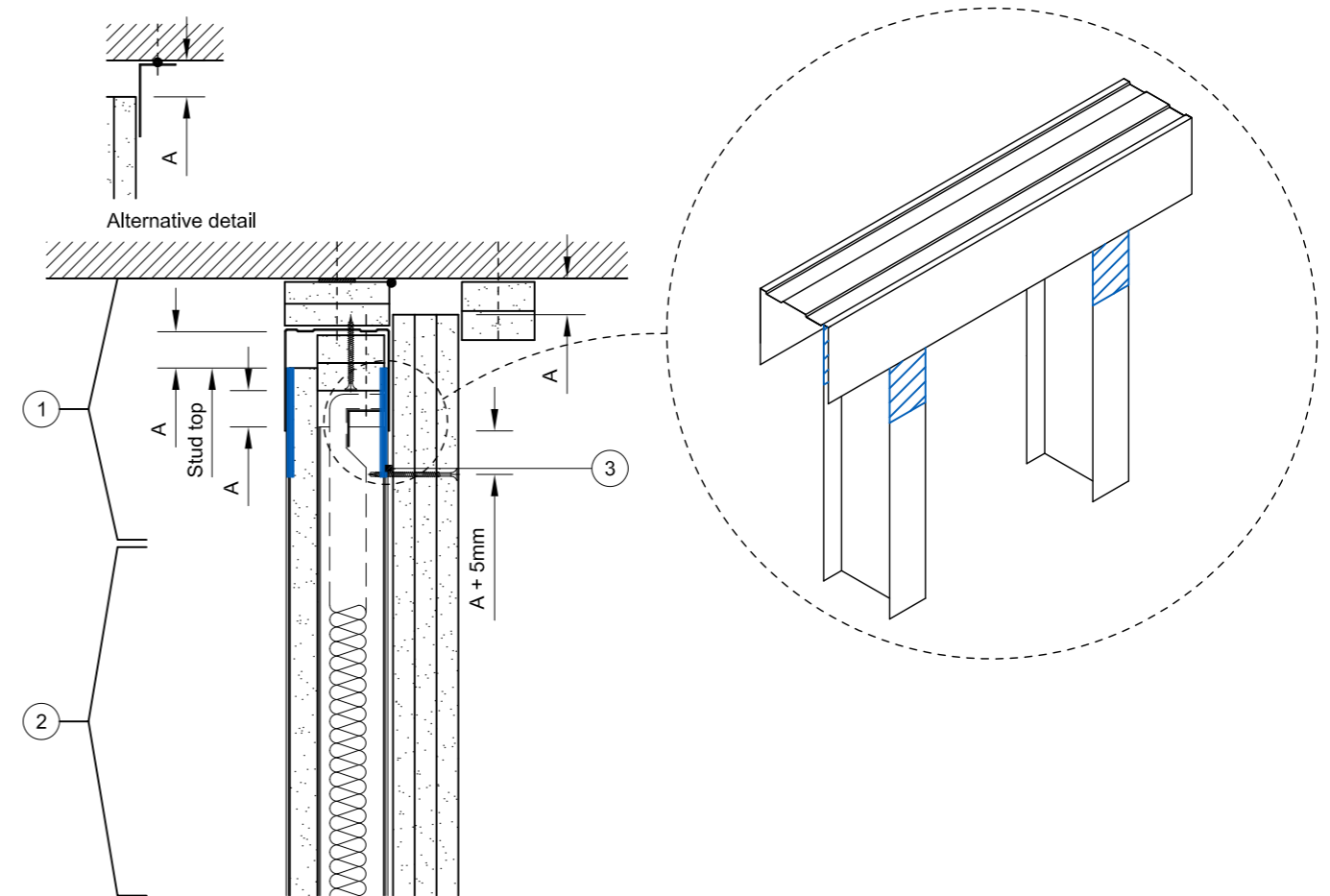

Deflection head

Downward (vertical) movement

A = Required project vertical deflection, to be determined by Structural Engineer, please refer to British Gypsum standard details for further guidance on permitted range of movement and detail configuration.

Section B – Ceilings

Detail 5 – GypCeiling MF with floating perimeter

- 1 Two layers Gyproc plasterboard or Glasroc specialist board fixed with suitable British Gypsum screws at 230mm centres in field of board and 150mm centres at board ends.
 - 2 Gyprframe MF5 Ceiling Sections at max. 450mm centres fixed to each MF7 with two suitable British Gypsum wafer head screws or MF9 Connecting Clip.
 - 3 Gyprframe MF6 Perimeter Channel fixed to each MF7 with suitable British Gypsum wafer head screws.
 - 4 Gyprframe MF7 Primary Support Channels at specified centres.
 - 5 Gyprframe MF8 Strap Hanger or FEA1 Steel Angle hangers at specified centres fixed to MF7 with two suitable British Gypsum wafer head screws.
 - 6 Gyprframe MF12 Soffit Cleat fixed to hanger with MF11 Nut and Bolt suitably fixed to soffit.
 - 7 Isover insulation where required.
 - 8 Gyproc Drywall Edge Bead.
 - 9 Gyprframe MF6 Perimeter Channel.
 - 10 To minimise loss of sound insulation and maintain fire resistance of system, cloak unfixed perimeter using stone mineral wool (33 Kg/m³) by others secured with Gyprframe FEA1 Steel Angle suitably fixed to wall at 600mm centres.
 - 11 Additional Gyprframe MF5 Ceiling Section at perimeter fixed to each MF7 with two suitable British Gypsum wafer head screws or MF9 Connecting Clip.
- As this is a junction where movement can occur, where both the ceiling and wall are to be skim finished it is recommended that the wall is skimmed before the ceiling installation. The ceiling finish can then be applied as required, maintaining the unfixed perimeter.**

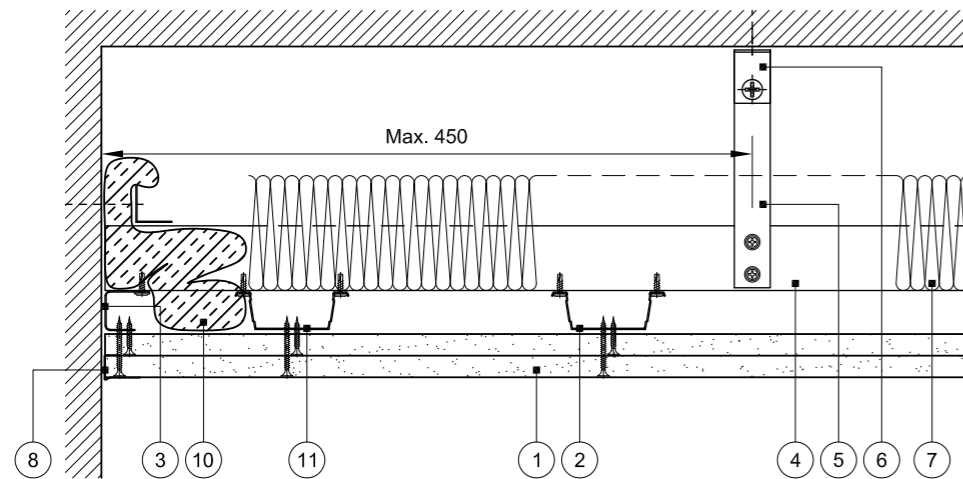

Unfixed perimeter 1

Gyprframe MF5 Ceiling Section parallel to wall.

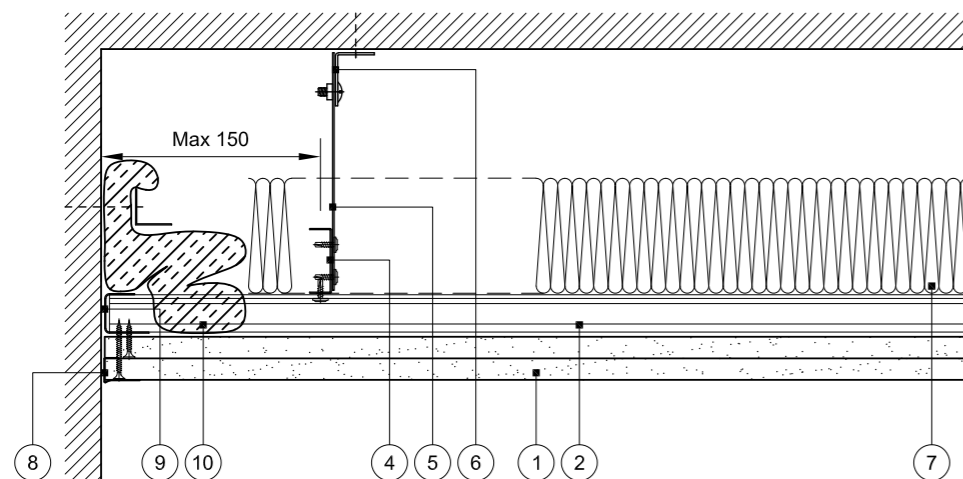

Unfixed perimeter 2

Gyprframe MF5 Ceiling Section perpendicular to wall.

Section B – Ceilings

Detail 6 – GypWall Single Frame junction with GypCeiling MF

- 1 GypCeiling MF system as per project specification and British Gypsum standard details, bound around perimeter by structural wall or full height GypWall partition spanning between structural floor and soffit.
- 2 GypWall partition deflection head detail as per project specification and required movement as determined by Structural Engineer, please refer to British Gypsum standard details.
- 3 GypWall partition system as per project specification and British Gypsum standard details.
- 4 Gyprframe MF5 Ceiling Sections at max. 450mm centres fixed to each MF7 with two suitable British Gypsum wafer head screws or MF9 Connecting Clip.
- 5 Additional Gyprframe MF5 Ceiling Sections as required to provide fixing ground for GypWall partition head channel fixings and deflection head cloaking elements fixings, fixed to each MF7 with two suitable British Gypsum wafer head screws.
- 6 75mm x 75mm Fric-Lo® 2020 5M Instant Friction Reduction Tape applied to top of each stud, on both flanges, prior to location of studs within head channel.

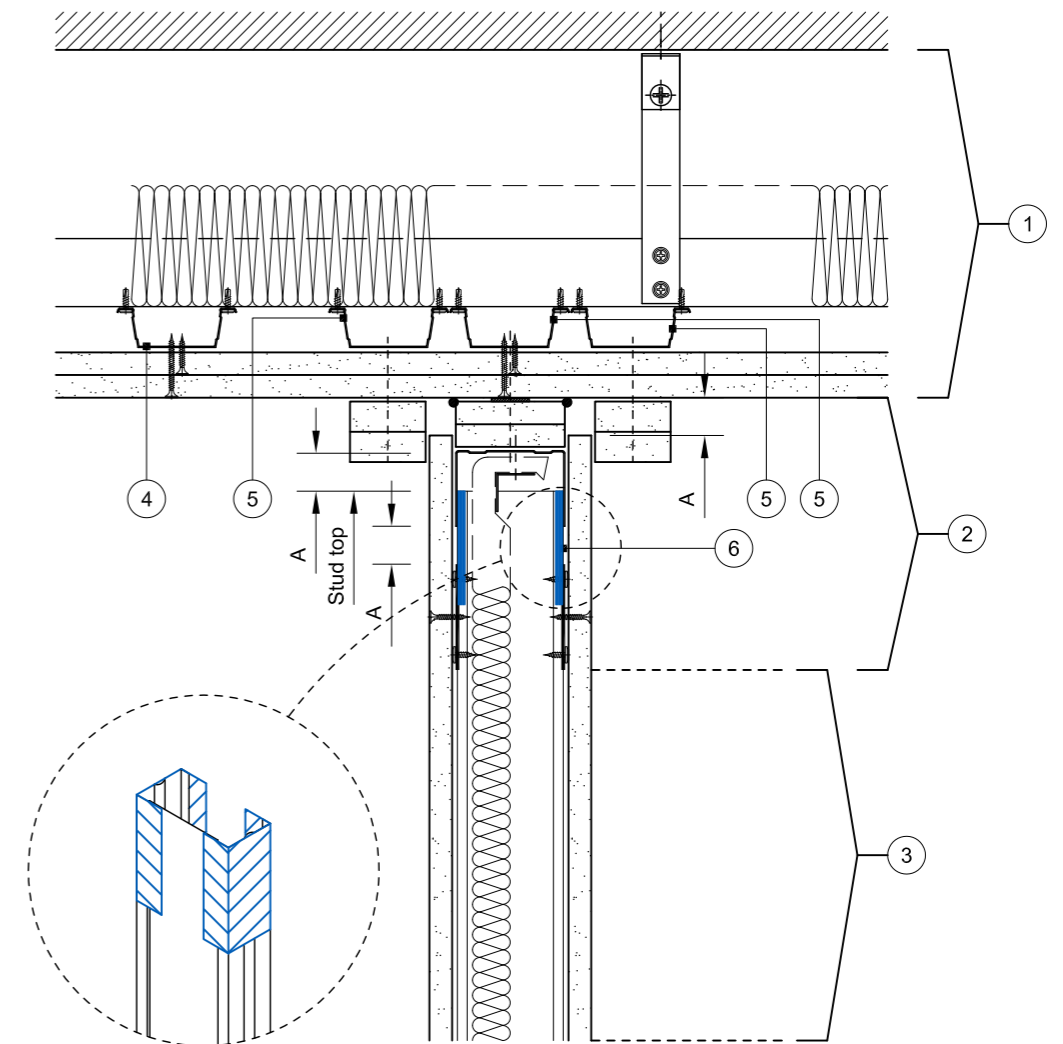

GypWall partion and GypCeiling MF Ceiling junction

A = Required project vertical deflection, to be determined by Structural Engineer, please refer to British Gypsum standard details for further guidance on permitted range of movement and detail configuration.

Section C – Abutments to superstructure

Detail 7 – Rip of plasterboard

- 1 Two layers Gyproc plasterboard or Glasroc specialist board fixed with suitable British Gypsum screws at 300mm centres (200mm centres at external angles).
- 2 Gypframe 'C' Studs at specified centres.
- 3 Isover insulation where required.
- 4 Gyframe Channel suitably fixed to floor at 600mm centres (in two lines staggered by 300mm for 94mm and 148mm channels).
Deep Channel for height between 4200mm and 8000mm or
Extra Deep Channel for heights over 8000mm.
- 5 Gyproc Sealant for optimum sound insulation.
- 6 Gypframe 'C' Stud suitably fixed through Gyproc plasterboard strip to wall at 600mm centres (in two lines staggered by 300mm for 92mm and 146mm studs).
- 7 Channel width strip of Gyproc plasterboard type to match partition specification, pre-fixed to stud with British Gypsum Drywall Screws at 300mm centres.

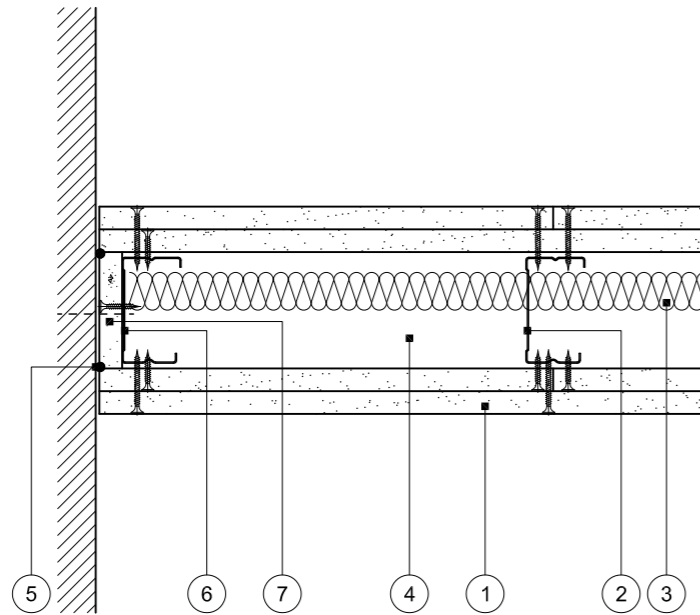

Wall abutment

Revisions

DATE	CHANGES
26 June 2024	Addition of new Gypframe LF7 Connector details, pages 5-7, 13, 14, 18
11 October 2024	Update to Gypframe LF7 detail, page 18
19 March 2025	Advisory note added regarding sequencing of plastering, page 22
12 January 2026	Amended text, page 3



“Gyproc”, “Thistle”, “ThistlePro”, “Gypframe” and “Glasroc” are all registered trademarks of Saint-Gobain Construction Products UK Limited. “Isover” is a registered trademark of Saint-Gobain Isover (French legal entity) and “Okarno” is a registered trademark of Okarno Limited.

Saint-Gobain Construction Products UK Limited is a limited company registered in England under company number 734396, having its registered office at Saint-Gobain House, East Leake, Loughborough, Leicestershire, LE12 6JU, UK. Saint-Gobain Construction Products UK Limited trades as British Gypsum for part of its business activities.

British Gypsum reserves the right to revise product specification without notice. The information herein should not be read in isolation as it is meant only as guidance for the user, who should always ensure that they are fully conversant with the products and systems being used and their subsequent installation prior to the commencement of work. For a comprehensive and up-to-date library of information visit the British Gypsum website at: british-gypsum.com. For information about products supplied by Okarno Limited or Saint-Gobain Isover please see their respective websites.

“British Gypsum” is a registered trademark of Saint-Gobain Construction Products UK Limited.